

KR SERIES

PROPERTIES

- Resistance to:** Ultraviolet rays, ozone, mineral oils, fuels, salts, alkalis, alcohol, hydrocarbons, ketones, ether, termites and radioactive rays*
- Flame resistance:** UL94 5VA (IEC 60695-11-20)
UL94 V-0 (IEC 60695-11-10)
IEC 61914 following IEC 60695-11-5
Classification following DIN 5510, part 2 Flammability class: S3
- Thermal expansion:** 0.01% per 10°C temperature increase
- Tensile strength:** 120 N/mm²
- Flexural strength:** 210 N/mm²

TEMPERATURE RANGE

- Ambient temperature:** down to -60°C*
- Continuous operation:** up to 120°C
- Permitted short-term heating:** up to 220°C
- Operation life:** more than 40 years of maintenance- and failure-free operation

MATERIAL

High-grade polyamide, fibreglass-reinforced, coloured black, with special UV protection, fully recyclable, self-extinguishing, low-smoke, zero halogen (LSZH), non-toxic, non-corrosive, non-metallic, non-magnetic

Applications:

Fastening of single- and multi-core cables for high short circuit fores. Unrestricted application indoors and outdoors between -60°C and +120°C. Fastening in single, parallel, stacked and bundled formation.

Outer diameter of cables:

70 mm to 250 mm

Dynamic resistance to short circuits:

30.000 N

Tightening Torque for fixing material:

Upper part: 8 Nm** / Lower part: 20 Nm

Dimensions in mm

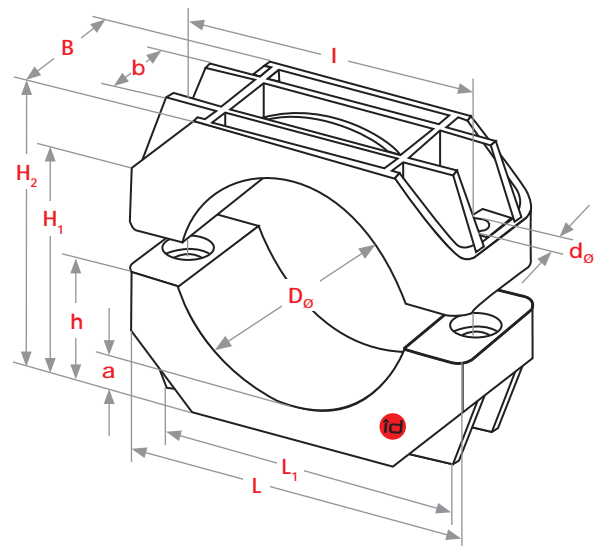

Type	D _ø	D _ø ++	L	L ₁	B	b	I	H ₁	H ₂	h	a	d _ø	Screw thread
KR 75/100	75-100	70-95	180	172	77	44	150	71-97	109-134	52	17	14	M12
KR 100/130	100-130	95-125	210	197	97	54	175	99-129	140-170	69	20	14	M12
KR 130/160	130-160	125-155	250	213	97	54	210	116-146	176-206	87	23	18	M16
KR 160/200	160-200	155-195	290	258	120	60	250	172-212	230-270	113	35	18	M16
KR 200/250	200-250	195-245	340	300	120	61	300	190-240	280-330	130	40	18	M16

D_ø: Outer cable diameter
D_ø++: - with two Elastic Inlays

* For more information please contact id-Technik
** Please contact id-Technik for trailing cables (EPDM, rubber, etc.).



STANDARD IEC 61914 id-Technik Cable Clamps have been type-tested by accredited test institutes to the international standard IEC 61914.

Legal compliance

- Directive 2015/863/EU (RoHS)
- Regulation (EC) No. 1907/2006 (REACH regulation)

Constructional features

- Particularly high dynamic and mechanical strength and heat resistance due to special fibreglass-reinforced polyamide
- Safe restraint of dynamic forces of high short circuit currents, without damage to the cables, also for multiple short circuits
- Type-tested to IEC 61914 – cable cleats for electrical installations - reports from accredited institutes regarding dynamic short circuit currents, the fire-resistance of the material, and mechanical properties of the Cable Clamps are available
- Very low surface pressure on cables due to Cable Clamps' large contact area
- Unrestricted application both indoor and outdoor in extreme climates such as deserts, tropics, high altitudes, arctic climate, coastal salt fogs, flooding and ozone due to special resistance to ageing, ultraviolet rays and ozone
- Easy to mount without special instruments and maintenance-free
- Fastening of Cable Clamps adaptable to all local conditions

Type-Tests to IEC 61914 on Series KR Cable Clamps approved results in highest classification

Classification	Test conditions	Approved results	Paragraph
Material: non-metallic	high-grade polyamide		6.1.2
Operating temperature	-60°C / +120°C	withstood	6.2
Resistance to impact	-60°C, 5 kg at 400 mm height	very heavy	6.3.5
Lateral load test (N) – in x-direction – in y-direction	+120°C	18.000 N 15.000 N	6.4.1
Axial load test (N) – with Elastic Inlays	+120°C	1.500 N	6.4.2
Dynamic resistance to short circuits (N) suited to withstand multiple short circuits	Peak short circuit current: 181 kA Cable Clamp spacing: 1,10 m	30.000 N	6.4.4
UV-resistance	high	passed	6.5.1
Flame propagation	1 x 30s, needle flame method	passed	10.1 (IEC 60695-11-5)
	2 x 10s, 50 W test flame method	V-0	UL 94 V (IEC 60695-11-10)
	5 x 5s, 500 W test flame method	5VA	UL 94 5V (IEC 60695-11-20)
	3 min	S3	DIN 5510

Use of Elastic Inlays:

- As a cushion for elastic adjustment of cable diameter changes due to operational load changes and/or changes in the ambient temperature
- Precise cable fixation and absorption of weight forces, primarily on cables installed along inclines or attached to vertical surfaces where restraint of axial movement is essential
- Compensation of vibrations, e.g. in wind turbines, without reducing retention forces
- Expansion of the Clamp's clamping area, for cables with a smaller outer diameter
- Elastic Inlay 100 mm x 100 mm for KR 75/100, KR 100/130
- Elastic Inlay 150 mm x 140 mm for KR 130/160, KR 160/200, KR 200/250