



# KT SERIES

100%  
MADE IN  
GERMANY

## PROPERTIES

Resistance to:	Ultraviolet rays, ozone, mineral oils, fuels, salts, alkalis, alcohol, hydrocarbons, ketones, ether, termites and radioactive rays*
Flame resistance:	UL94 5VA (IEC 60695-11-20) UL94 V-0 (IEC 60695-11-10) IEC 61914 following IEC 60695-11-5 Classification following DIN 5510, part 2 Flammability class: S3
Thermal expansion:	0.01% per 10°C temperature increase
Tensile strength:	120 N/mm <sup>2</sup>
Flexural strength:	210 N/mm <sup>2</sup>

## TEMPERATURE RANGE

Ambient temperature:	down to -60°C*
Continuous operation:	up to 120°C
Permitted short-term heating:	up to 220°C
Operation life:	more than 40 years of maintenance- and failure-free operation

## MATERIAL

High-grade polyamide, fibreglass-reinforced, coloured black, with special UV protection, fully recyclable, self-extinguishing, low-smoke, zero halogen (LSZH), non-toxic, non-corrosive, non-metallic, non-magnetic

## Applications:

Fastening of single- and multi-core cables, for high short circuit fores. Unrestricted application indoors and outdoors between -60°C and +120°C. Fastening in single, parallel, stacked and bundled formation.

## Outer diameter of cables:

19 mm to 39 mm

## Dynamic resistance to short circuits:

25.000 N

## Tightening Torque for fixing material:

Upper part: 5 Nm\*\*  
Lower part: 20 Nm

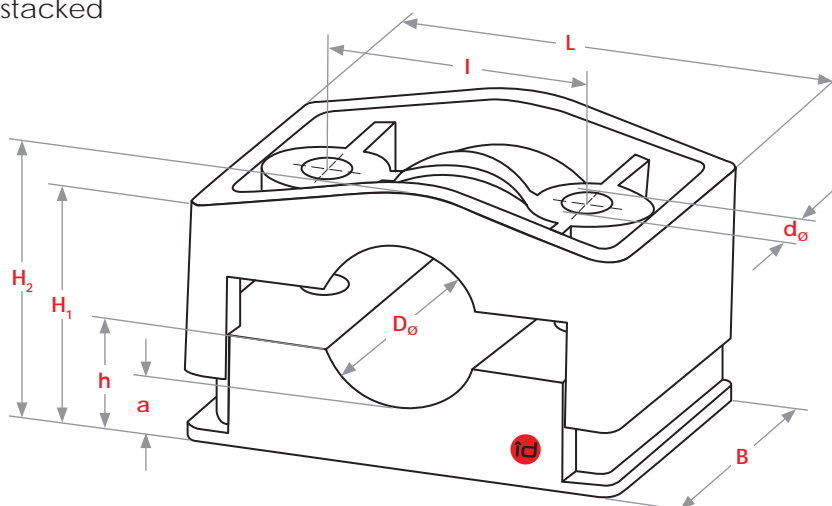

## Dimenzije v mm

Tip	D <sub>0</sub>	D <sub>0+</sub>	D <sub>0++</sub>	L	B	I	H <sub>1</sub>	H <sub>2</sub>	h	a	d <sub>0</sub>	Navoj vijaka
KT 25/39	25-39	22-36	19-33	107	60	65	46-60	55-69	27	15	13	M12

D<sub>0</sub>: Zunanji premer kabla

D<sub>0+</sub>: - z eno elastično podlogo

D<sub>0++</sub>: - z dvema elastičnima podlogama

\* Za več informacij kontaktirajte PETEZE d.o.o.

\*\* Glede pritrdjevanja kablov (EPDM, gumi, itd.) prosim pokličite PETEZE d.o.o.

PETEZE d.o.o., distributer za Slovenijo in Hrvaško, Jama 15, SI-1234 Mengeš, Slovenija,  
Tel.: +386 (1) 833 25 90, Fax: +386 (1) 833 25 99, www.peteze.si, info@peteze.si

Za dodatne podrobnosti se obrnite na id-Technik. Tehnične spremembe in napake pričižane. Datum 12/2019. Informacije, predstavljene v teh priročnikih, so namenjene usmerjanju pooblaščenih uporabnikov izdelkov id-Technik. Avtorske pravice in pravice intelektualne lastnine varujejo vsi vsebino priročnikov in katalogov id-Technik. Vključno z vsem besedilom, risbami, slikami in drugimi predstavitvenimi izdelki. Kaznivo je kopiranje, komuniciranje ali drugačna uporaba teh lastniških podatkov ni dovoljena brez predhodnega pisnega soglasja družbe id-Technik GmbH.



**STANDARD IEC 61914** id-Technik Cable Clamps have been type-tested by accredited test institutes to the international standard IEC 61914.

### Legal compliance

- Directive 2015/863/EU (RoHS)
- Regulation (EC) No. 1907/2006 (REACH regulation)

### Constructional features

- Particularly high dynamic and mechanical strength and heat resistance due to special fibreglass-reinforced polyamide
- Safe restraint of dynamic forces of high short circuit currents, without damage to the cables, also for multiple short circuits
- Type-tested to IEC 61914 – cable cleats for electrical installations - reports from accredited institutes regarding dynamic short circuit currents, the fire-resistance of the material, and mechanical properties of the Cable Clamps are available
- Very low surface pressure on cables due to Cable Clamps' large contact area
- Unrestricted application both indoor and outdoor in extreme climates such as deserts, tropics, high altitudes, arctic climate, coastal salt fogs, flooding and ozone due to special resistance to ageing, ultraviolet rays and ozone
- Easy to mount without special instruments and maintenance-free
- Fastening of Cable Clamps adaptable to all local conditions

### Type-Tests to IEC 61914 on Series KT Cable Clamps approved results in highest classification

Classification	Test conditions	Approved results	Paragraph
<b>Material:</b> non-metallic	high-grade polyamide		6.1.2
<b>Operating temperature</b>	-60°C / +120°C	withstood	6.2
<b>Resistance to impact</b>	-60°C, 5 kg at 400 mm height	very heavy	6.3.5
<b>Lateral load test (N)</b> – in x-direction – in y-direction	+120°C	20.000 N 30.000 N	6.4.1
<b>Axial load test (N)</b> – without Elastic Inlays – with Elastic Inlays	+120°C	600 N 800 N	6.4.2
<b>Dynamic resistance to short circuits (N)</b> suited to withstand multiple short circuits	Peak short circuit current: 151 kA Cable Clamp spacing: 0,84 m	25.000 N	6.4.4
<b>UV-resistance</b>	high	passed	6.5.1
<b>Flame propagation</b>	1 x 30s, needle flame method	passed	10.1 (IEC 60695-11-5)
	2 x 10s, 50 W test flame method	V-0	UL 94 V (IEC 60695-11-10)
	5 x 5s, 500 W test flame method	5VA	UL 94 5V (IEC 60695-11-20)
	3 min	S3	DIN 5510

### Use of Elastic Inlays:

- As a cushion for elastic adjustment of cable diameter changes due to operational load changes and/or changes in the ambient temperature
- Precise cable fixation and absorption of weight forces, primarily on cables installed along inclines or attached to vertical surfaces where restraint of axial movement is essential
- Compensation of vibrations, e.g. in wind turbines, without reducing retention forces
- Expansion of the Clamp's clamping area, for cables with a smaller outer diameter