

Distance Wedge

For Cable Clamp series KH:

Application: Additional fixation of cables for high- and extra high-voltage in trefoil formation, especially with impregnated paper insulation and at vertical installations

Range of outer cable diameter: 57 mm to 112 mm

Material: Polyamide, fibreglass-reinforced

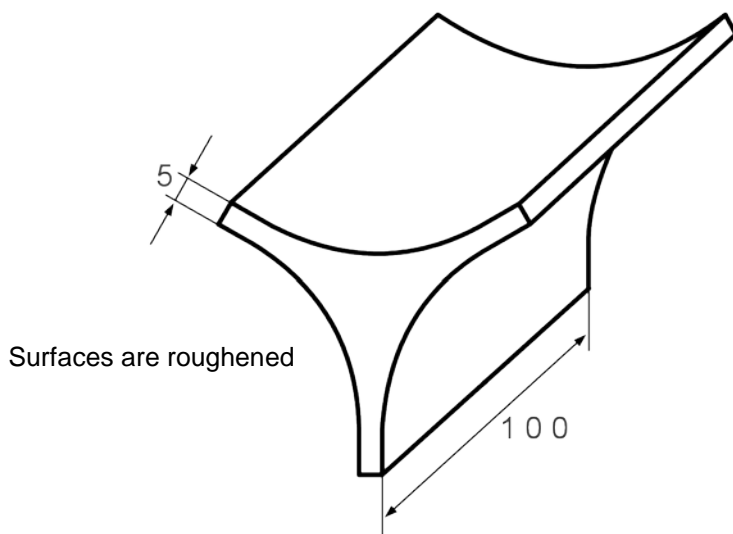

Wedge Type	D _∅	Clamp Type
S 57/92	57 - 70	KH 62/75
	68 - 81	KH 73/86
	79 - 92	KH 84/97
S 90/112	90 - 102	KH 95/107
	100 - 112	KH 105/117

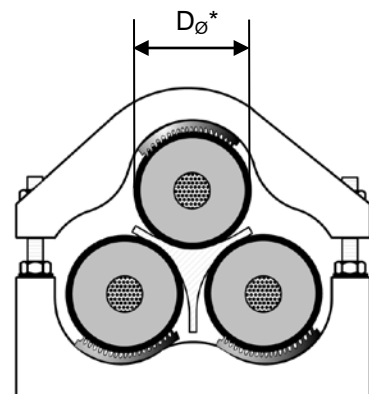

D_∅: outer diameters of the single cables using Distance Wedge and Elastic Inlays