

# HSS-150/SEG/D/DG

## Fire protection kit S 90 for HSI 150 wall seals

DIBT approval  
Z-19.15-1906  
to DIN 4102-9



Article code:  
HSS-150/SEG/D/DG

### Features and technical data:

- S90 retrofitting for pressure-tight wall seals
- fire protection combination with SEGMENTO, shrink sleeve and HSI 150-DG
- approval for bundles with HSI 150 up to 2x6
- min. fire barrier spacing 440 mm
- from wall thickness 240 mm
- no limits on individual cable diameters
- weather-proof fire-stop pads
- pads can be installed from one side
- high degree of flexibility as regards to subsequent assignment

### The correct way to quote the article code:

Complete fire protection kit for HSI 150  
for SEGMENTO seal system, shrink sleeve and HSI 150-DG:

### Article code: HSS-150/SEG/D/DG

- 1 set of HVS pads for full assignment (without cable)
- 1 x stainless steel clamping straps
- 1 x identification sign
- 1 x processing instructions and DIBT approval [Germany]

Delivery of the HVS fire-stop pads without wall insert and system cover.  
The wall insert and the system cover must be ordered separately.

### HSS-150/SEG/D/DG fire protection kit

Combined with the Hauff HSI 150 wall entry system and the tried-and-tested modular gas- and watertight system seals, the HVS fire-stop pads form the new HSS Hauff fire safety system. The HSS system provides safe S90 fitting, while also saving time and costs, for construction projects with complex fire protection requirements in accordance with DIN 4102-9.

Using the practical HSS-150 fire protection kit, HVS fire-stop pads can be inserted cleanly and tautly from one side in the HSI 150 wall insert, either during or after sealing with SEGMENTO, shrink sleeve or HSI 150-DG. In addition to providing a reliable gas- and watertight seal for cables of all kinds, this enables later upgrading to reliable S90 fire protection capability.

# HSS-150/SEG/D/DG

## Technical data

<b>DIBT approval number [Germany]</b>	Z-19.15-1906					
<b>Fire resistance rating</b>	S90 according to DIN 4102 Part 9 / 90 minutes					
<b>Areas of application</b>	S90 sealing with the HSI 150 system for projects with high requirements for gas- and watertight wall penetrations, e.g. in energy supply and distribution systems, the chemicals industry, in biogas and sewage treatment plants, rooms with fire extinguishing systems, underground parking, false floors and cable access chambers, etc. Sealing for cables of all types and diameters (except waveguide cables). Cables for control purposes up to 12 mm. In walls made from concrete, reinforced concrete, aerated concrete or masonry.					
<b>System seals</b>	System cover for HSI 150: HSI 150-D7/33, HSI 150-D 3/58, HSI 150-D1/80, HSI 150-S3, HSI 150-DG					
<b>Dimensions/clearances</b>	<b>Wall thickness/ fire barrier spacing</b>	<b>Clearance</b>	<b>Max. assignments</b>			
	≥ 240 mm ≥ 440 mm	distance from edge ≥ 10 mm	see table in approval: SEGMENTO attachment 6, shrink-fit sleeves: attachment 7 system cover HSI 150-DG: attachment 8			
<b>Fire barrier spacing</b>	5 cm for single entries, 20 cm for bundles					
<b>Fire-stop pads Packing unit longitudinal installation</b>	<b>Type</b>	<b>Area</b>	<b>Filling weight</b>	<b>Dimensions LxWxH</b>	<b>Packing unit</b>	<b>Article code</b>
	250/2*	23 cm <sup>2</sup>	250 g	340 x 90 x 25 mm	30 pcs.	HVS-K-250/2
	400	32 cm <sup>2</sup>	400 g	340 x 180 x 20 mm	22 pcs.	HVS-K-400
	720	63 cm <sup>2</sup>	720 g	340 x 180 x 35 mm	12 pcs.	HVS-K-720
	60*	8 cm <sup>2</sup>	60 g	360 x 50 x 10 mm	30 pcs.	HVS-KB-60
<b>Notes</b>	HVS-STB stainless steel clamping straps (accessory) are required for wall thicknesses up to 350 mm and have to be ordered separately if you have only ordered the pads.					
<b>Accessories</b>	HVS-HSS-BM: fitting panel for close-fitting installation of HVS/HSS fire-stop pads HVS-STB: 10 stainless steel clamping straps HVS-VA: processing instructions, DIBT approval [Germany] and 2 identification signs HVS-KS: 1 universal identification sign					
<b>Fire protection kit SEGMENTO, shrink-fit sleeves and HSI 150-DG</b>	Scope of delivery for pads: 1x HVS-K-720; 1x HVS-K-400; 4x HVS-K-250/2; 4x HVS-KB-60					

\*with installation kit

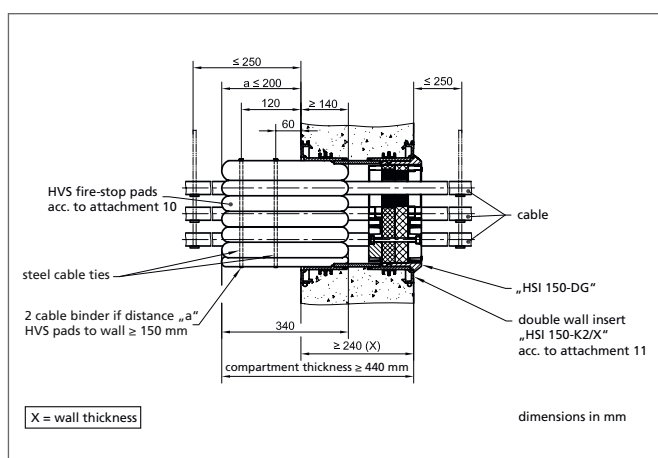

Sectional view of fire safety system (Example with HSI 150-DG)

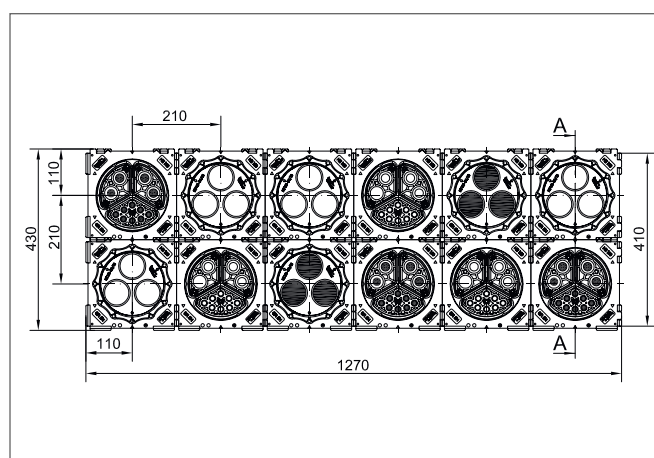

Modular fire safety system max. dimensions with bundle